

PURCHASE AGREEMENT, FULL ASSUMPTION OF LIABILITY AND INDEMNITY AGREEMENT

User acquires from KingTech, or from one of KingTech's authorized dealers, a MINIATURE TURBOJET ENGINE for model aircraft, agrees to all of the following terms and conditions:

1. User's Representations. User represents that he/she is very experienced in model airplane operation, and that all of the information set forth is true and correct. KingTech relies on such representations, and would not enter into this transaction but for these representations.
2. User acknowledges the Risks and Dangers involved. User recognizes that operation of the Model Engine may be dangerous, and that under certain circumstances, its handling will be dangerous. As set forth in Paragraph 3 below, User accepts full responsibility for all of these risks and waives all liability against KingTech.
 - a. User's Acknowledgment of Danger. User expressly acknowledges that use of the Model Engine is dangerous if improperly handled, and could inflict injury if attempts are made to handle it properly, if the user does not fully acquaint himself/herself with the Model Engine's operation procedures. The Model Engine may cause burns to the user, or the user's assistant, particularly in the start-up procedure, and user agrees to use extreme caution. The Model Engine exhaust is extremely hot, and will burn someone or something placed directly behind the exhaust tube. Highly flammable liquid is used to operate the Model Engine, and it or its fumes will ignite easily and flare up rapidly. The Model Engine itself remains extremely hot, after it is shut off, and requires a cooling down period. Improper use of the Model Engine, or failure to follow Academy of Model Aeronautics ("AMA") guidelines and rules will result in injury to the user, the user's

- assistant, or bystanders. Operation of the Model Engine in any location other than an approved location, and under safe circumstances could lead to injury to bystanders. A risk exists from explosion, in the event of tampering, modifications leading to over-speed or extreme metal fatigue.
- b. User's Obligation to Become Fully Acquainted With Operation Procedure. User acknowledges receipt of operating instructions for the Model Engine which depicts its handling and operation. User agrees to thoroughly acquaint himself/herself with these materials, and to require his/her assistant to become equally familiar with them. User expressly agrees not to allow any person to assist in the start-up procedure of the Model Engine, who has not become thoroughly familiar with these materials.
 - c. Agreement to Use Qualified Assistant in Start-Up Procedure. User acknowledges that the start-up procedure for the Model Engine cannot be safely done without an assistant. User expressly agrees to use an assistant, who is thoroughly familiar with the Model Engine and its operation as set forth above, on each occasion when the Model Engine is starting up.
 - d. Warning to Bystanders. User acknowledges that injury or burns to bystanders could occur, during the start-up procedure or when operating the Model Engine. User expressly agrees to take all steps necessary to assure that no bystander will be in a position to receive injuries during the start-up procedure, or while the Model Engine is running.
3. Full Assumption of Liability; Waiver and Release of KingTech. User assumes all risks of injury, harm and damages, of every nature whatsoever, to himself/herself and his/her property. User fully and completely waives and releases any and all claims which he/she might have at any time arising out of

the purchase, handling, or operation of the Model Engine. This assumption, waiver and release is complete, full, and comprehensive.

- a. Release Even If KingTech Is Negligent. The waiver and release contained herein releases KingTech from all conduct, no matter how it could be characterized or alleged. KingTech shall not be liable based on any theory in strict liability in tort. KingTech shall not be liable for any alleged breach of warranty, whether express or implied, of any nature whatsoever, whether a warranty of fitness for a particular use, merchantability, or otherwise.
 - b. Waiver Effective for All Time. The waiver and release contained herein is effective, without regard to the passage of time. It is effective indefinitely. It will not be changed by any modification to the Model Engine, to any later resold, or other changes in any circumstances.
 - c. Release Extends to KingTech and All Its Associates. The waiver and release contained herein protects KingTech, and all of its employees, officers, principals, owners, importers, distributors, dealers, designers, and agents ("Associates").
4. No Modifications to Model Engine. User agrees to make no modifications of any kind to the Model Engine. This Agreement pertains to the entire life of the Model Engine.
 5. Sale By User to Other Party. User agrees to fully inform any person to whom he/she sells or transfers the Model Engine, concerning the handling, use, and operation of the Model Engine, and agrees to give all operating instructions to such person, at or before the time of sale or transfer. The indemnity and hold harmless agreement contained in Paragraph 3 continues in effect, following such sale or transfer.
 6. Severability. In the event any clause, provision, or term of this Agreement is held to be ineffective, void or otherwise unenforceable for any reason, that clause, provision, or term shall be severed from this Agreement, and the Agreement shall otherwise remain binding and effective. If any portion

of Paragraph 3 is found to be unenforceable, then the parties agree that the fullest and most complete waiver and release, which is permitted by law, shall be effective.

7. No Interpretation of Agreement Against Either Party. User understands and expressly acknowledges that he/she has the right to have an attorney read and review this Agreement, before execution. This Agreement shall not be interpreted against either party, but shall be interpreted as if it was drafted mutually by the parties.
8. KingTech reserves the right to void warranty to an individual if one chooses to make a negative public announcement before contacting us and allowing us opportunity to assist or correct.
9. Make certain to comply all local rules, and obtain local licensing, permit, or waiver to operate a turbine engine.
10. KingTech Turbines reserves the right to terminate support to those who are defiant and in compliant to our ways of operations.
11. If the Buyer is not prepared to fully accept the PURCHASE AGREEMENT, FULL ASSUMPTION OF LIABILITY AND INDEMNITY AGREEMENT, the Buyer is advised to return this Model Engine immediately in new and unused condition to the place of purchase.
12. Engine sent in for crash repair or misuse is subject to a \$50 inspection fee (inspection fee waived if work is authorized) and return shipping charge.
13. We reserve the right to ensure all repairs are up to factory spec including cosmetics, quality or level of repair is not to be negotiated nor compromised.
14. Any engine sent in not reclaimed within 90 days will be considered abandoned and will be dismantled, disposed or recycled.
15. Terms and conditions may change without notice. Buyers are to accept the latest terms and conditions with no exceptions, which is to be found at: www.kingtechturbines.com.

KingTech * Limited Lifetime Warranty *

KingTech warrants that this MINIATURE TURBOJET ENGINE for model aircraft, cars or boats ("Model Engine") enclosed with this warranty statement is free from defects in materials and workmanship during normal usage, according to the following terms and conditions.

1. The limited warranty extends to the original purchaser ("Buyer") of the Model Engine and is transferable with no fees during the first year of the original purchase, after the first year, a warranty transfer fee of \$150 is required to any subsequent purchaser / end-user. Though it may still not have the warranty in place, all engines must be registered with us at www.kingtechturbines.com to receive any type of support.
2. Warranty coverage begins the day you bought the turbine to the day you sold or lost the turbine, all electrical components such as batteries, electric starter motor, glow plug, valves, ECU, GSU, pump and all frictional materials and components will have a one year warranty coverage including but not limited to that of the bearings. All parts, including repaired and replaced parts are covered for the original warranty period. When the warranty on the turbine expires, the warranty on all replaced and repaired parts also expires. The engine core, including but not limited to that of combustion chamber, shaft, shaft tunnel, diffuser, injectors, NGV, turbine wheel, will enjoy lifetime warranty and may or may not be replaced or upgraded during interval services.
3. Buyer must fully accept all conditions of the PURCHASE AGREEMENT, FULL ASSUMPTION OF LIABILITY AND INDEMNITY AGREEMENT
4. During the warranty period KingTech will repair or replace, at KingTech's option, any defective parts with new or factory rebuilt replacement items if such repair or replacement is needed because of Model Engine malfunction or failure during normal usage. No charge will be made to the Buyer for any such parts. KingTech will also pay for the labor charges incurred by KingTech in repairing or replacing the warranted parts and or components. The limited

warranty does not cover defects in appearance. KingTech will not be liable for any other losses or damages.

5. Upon request from KingTech, the Buyer must prove the date of the original purchase of the Model Engine by a dated bill of sale or dated itemized receipt.
6. Buyer must bear the cost of shipping the turbine to KingTech, Taiwan or KingTech Turbines International in Pasadena, California.
7. Buyer shall have no coverage or benefits under this lifetime warranty if any of the following conditions are applicable
 - a. The Model Engine has been subject to abnormal use, abnormal conditions, improper storage, unauthorized modifications, unauthorized repair, misuse, neglect, abuse, accident, alteration, improper installation, fail to engage into proper cool down, or other acts which are not the fault of KingTech, including damage caused by shipping.
 - b. The Model Engine has been damaged from external causes such as crash damage, foreign object damage, weather, Act of God, improper electrical connections, or connections to other products not recommend for interconnection by KingTech.
 - c. The Model Engine is operated for commercial or institutional use.
 - d. The Model Engine serial number has been removed, defaced or altered.
8. If a problem develops during the warranty period, the Buyer shall take the following step-by-step procedure:
 - a. The Buyer shall ship the Model Engine prepaid and insured to KingTech, Taiwan or KingTech Turbines International in United States.
 - b. The Buyer shall include a return address, daytime phone number, complete description of the problem and proof of purchase.
 - c. The Buyer will be charged for any parts and/or labor charges not covered by this warranty.
 - d. If the Model Engine is returned to KingTech during the warranty period, but the problem with the Model Engine is not covered under the terms

and conditions of this warranty, the Buyer will be notified and given an estimate of the charges the Buyer must pay to have the Model Engine repaired, with all shipping charges billed to the Buyer. If the estimate is refused, the Model Engine will be returned freight collect plus cost of estimate generally \$50. If the Model Engine is returned to KingTech after the expiration of the warranty period, KingTech's normal service policies shall apply and the Buyer will be responsible for all charges.

9. KingTech shall not be liable for delay in rendering service under the limited warranty, or loss of use during the period that the Model Engine is being repaired.
10. KingTech neither assumes nor authorizes any other person or entity to assume for it any other obligation or liability beyond that is expressly provided for in this limited warranty.
11. This is the entire warranty between KingTech and the Buyer, and supersedes all prior and contemporaneous agreements or understandings, oral or written, and all communications relating to the Model Engine, and no representation, promise or condition not contained herein shall modify these terms.
12. This lifetime warranty allocates the risk of failure of the Model Engine between the Buyer and KingTech. The allocation is recognized by the Buyer and is reflected in the purchase price of the Model Engine.
13. If and when the bearings require replacement and ECU timer set back to zero during a warranty repair, customer is to be responsible for the charges of interval service at a prorated amount for the hours used.
14. Terms and conditions of warranty and liability may change without notice; users are to accept the latest terms and conditions with no exceptions.

TABLE OF CONTENTS

INTRODUCTION.....	9
SAFETY PRECAUTIONS.....	10
THE CHECKLIST.....	12
BEFORE RUNNING THE TURBINE.....	12
AFTER STOPPING THE TURBINE.....	12
FUEL and OIL / FUEL CARE.....	13
FUEL SYSTEM.....	14
HOPPER TANK.....	15
PRIME THE PUMP AND SYSTEM.....	15
FUEL SYSTEM CONNECTION DIAGRAM.....	16
FUEL PUMP ADJUSTMENT.....	16
MOUNTING THE TURBINE.....	17
CONNECTIONS AT THE TURBINE.....	18
ECU BATTERY (not included).....	20
DESCRIPTION OF THE ECU.....	21
SETTING UP THE ECU.....	23
“LEARN R/C”. TEACH THE ECU TO THE R/C SYSTEM.....	25
THROTTLE CURVES.....	26
TEST FUNCTIONS.....	27
TURBINE STARTING / RUNNING.....	38
TURBINE STOPPING / COOL DOWN.....	30
RUN MENU	31
LIST OF FADEC STATUS MESSAGE CODES.....	33
LIST OF FADEC WARNING MESSAGE CODES.....	34
DIAGNOSES.....	35
SPEifications.....	36
MAINTENANCE CYCLE.....	45
COMPONENTS LIST.....	46
KINGTECH TURBINES FUEL START OPERATING GULDE.....	47
KINGTECH TURBOPROP OPERATING GUIDE.....	48
FUEL START PARAMETERS.....	53
TROUBLESHOOT.....	54
CONTACT DETAILS	55

Introduction

Congratulations, you have just purchased a turbo-jet engine from KingTech Turbines, with the highest standards and technologies in turbine design and manufacturing. We will provide you with the best after-sales customer support and service to ensure you with many years of enjoyment with this new turbine engine. ***Please take a moment to properly register your engine at www.kingtechturbines.com.**

Obviously, model turbine aviation - despite all the apparent fun involved - has its potential dangers. All Kingtech turbine engines have been through an extensive period of R&D and testing.

To begin, read this manual thoroughly. Develop an overall impression of the engine and its operating procedures, measuring equipment and accessories.

Study the material step-by-step and ascertain how to install, operate and maintain your turbine engine. If you are unsure about anything, re-read it again or contact us directly.

DO NOT OPERATE THE TURBINE BEFORE YOU HAVE READ THE MANUAL AND FULLY UNDERSTAND EVERY PROCEDURAL DETAIL

Once you are accustomed to handling the Kingtech turbine, you will observe that it is a very reliable engine. Some experienced operators have expressed their belief that it handles better than many piston engines. However, always remember, this is a REAL JET ENGINE, requiring knowledge, discipline and maintenance.

In order to learn more about the development of the model turbine engine and understand its function, we highly recommend reading *Gas Turbine Engines for Model Aircraft* by Kurt Schreckling and *Model Jet Engines* by Thomas Kamps. These books are available through:

Traplet Publications

Traplet House

Severn Drive

Upton upon Severn, Worcestershire ISBN 0 9510589 1 6

United Kingdom WR8 0JL ISBN 0 9510589 9 1

Safety Precautions

ALWAYS ENFORCE THE PROPER MINIMUM SAFE DISTANCES FROM THE TURBINE!

In front of ~ 15 feet, On the side (perpendicular to the engine thrust) ~ 25 feet,

Behind ~ 15 feet

Fire extinguishers should be on hand at all times. We recommend the CO2 variety.

To avoid hearing damage, always use ear protection when you are near a running turbine engine.

When the turbine is running, never place your hands into the area of the intake. An extreme suction - which can grasp a hand, fingers or other objects in a flash – prevails in this area. Be aware of this source of danger, always!

Prevent foreign materials from entering the intake or exhaust when working with the turbine. Before operation, make sure there are no loose parts or debris near the turbine or within the fuselage. Objects being sucked in will cause severe damage to the engine, which will not be covered by any warranty; furthermore, such damage may also injure.

Always exercise caution around the hot parts of the turbine, to avoid burns. The outer case at the turbine stage and nozzle reaches 450-500° (Celsius), while the exhaust gas may exceed 750 °C.

Ensure that the fuel is mixed with approximately 5% approved oil. Use only turbine oils by KingTech Special Blend with Synthetics, which is a non-carcinogenic blend and available at www.kingtechturbines.com or turbine oil with MIL-PRF-23699 available at local airport fuel suppliers.

Never run the turbine in a closed room, or an area near any kind of flammable matter.

Do not fly turbine-powered aircraft near flammable materials, nor in forested tracts or areas experiencing drought or dryness. Obey all forest fire regulations and warnings by refraining from operating turbine in restricted fire zones. Never operate model turbine jet aircraft in or around residential or heavily populated areas.

Installation of unauthorized parts from another manufacturing source may also result in engine failure.

Warning:

A flying model with a turbine can reach higher flight speeds than ducted fan-powered models, because the turbine's thrust degrades less with higher flight speeds. With attainable flight speeds of up to 200 MPH or over, you can quickly run out of flying space. There is also a danger of developing control surface flutter or mechanical overload, causing the model to fail in flight. When piloting a turbine powered aircraft, one must properly control the throttle. Full power should be used for takeoff or vertical maneuvers and a reduced setting for level or descending flight. Please abide AMA flight rules of maintaining less than 200 MPH at all times.

The Checklist

Before Running the Turbine

- Charge ECU Battery
- Observe all safety precautions on Page 10
- Prepare fire extinguisher
- Check fuel lines and filter. Make sure they are clean with no restrictions
- Check that the fuel tank vent is unobstructed
- Fill fuel tank(s). Make sure the main and header tanks are full
- Prime pump. Take good care not flooding turbine, (this is only necessary after initial set up)
- Be certain the starting gas release valve is closed, before filling the starting gas tank
- Turn on receiver switch
- Place the model with nose into the wind
- Activate brakes and now you ready to start.

After Stopping the Turbine

- Turn model into the wind. Activate brakes and stop turbine
- After the cooling process (approximately two minutes), turn off receiver switch
- In the event that the turbine does not go into the cooling mode, please refer to page 28 for manual activation.
- After each flying session, open starting gas release valve, to empty the tank, before storing the model. This should be executed in a safe and well ventilated area

Fuel and Oil/ Fuel Care

KingTech engines use Diesel, 1-K kerosene or Jet-A1 for fuel. Fuel must be mixed with 5% KingTech Special Blend or synthetic turbine oil (Aeroshell 500 and all 2-stroke oil are prohibited), or 1 quart of oil in every 5 gallons of fuel. Among the above 3 types of fuel KingTech highly recommends using regular pump Diesel as they are readily available, inexpensive and having a higher energy density and up to 10 to 12% better fuel efficiency. For best result and full core warranty, use KingTech Oil only, it is proven to be the cleanest and has the best lubrication properties for our engines, please refer to the below comparison chart:

Engine Oil Comparison from KingTech Turbines

	Lubrication	Non-Coking	Non-carcinogenic	Eligibility for 25 hr I.S.	Full Lifetime Warranty	No additional labor required
2 Stroke oils	★★★★★	★★★★★	√		*	
Aeroshell 500	★★★★★	★★★★★			*	
Aeroshell 560	★★★★★	★★★★★		√	√	***
BP 2197	★★★★★	★★★★★		√	√	***
BP 2380	★★★★★	★★★★★		√	√	***
JetCat oil	★★★★★	★★★★★	√	√	√	***
KingTech oil	★★★★★	★★★★★	√	√	√	√
Mobil DTE	★★★★★	★★★★★	√	**	√**	√
Mobil Jet II	★★★★★	★★★★★		√	√	***
Tellus 32	★★★★★	★★★★★	√	**	√**	√

* The use of Aeroshell 500 and 2 Stroke oil will void warranty.

** Running Mobil DTE, Tellus 32 or their equivalent would cause excessive bearing noise and failure, recommended to be sent in for service between 15 to 20, hours. Warranty voids beyond 20 hours.

*** Due to excessive coking, up to 1 hour extra labor charge may apply to the use of Aeroshell 560, BP 2197, BP 2380, JetCat oil and Mobil Jet II

Fuel System

The input and output fuel tubing must be connected to the electronic shut-off valve as per the diagram on page 16, except the G model which is built in to the turbine.

When installing the fuel lines on components with barbed connectors, slightly heat the tubing and lubricate the barbs before connecting. This will soften the tube slightly, making it much easier to install. Double looping safety wire on all barbed connection is also required. To remove tubing from barbed connectors, you must cut the tubing off. Be careful not to damage the barbs when cutting off tubing. This could be done by snipping away the tubing material parallel at the fitting. To insert tubing into a Pisco or Festo quick release fittings, put a drop of oil on the outside of the tubing and use firm pressure until you feel the tube snaps in then lightly pull on the front ring and tubing to ensure a good seal. To release, press in on the front ring, while slightly pushing the turning the tubing then pull the tubing out for a clean release.

ALWAYS use a gasoline-compatible stopper. Silicon stoppers swell and leak.

Check your fuel filters every ten or so flights. The filter is installed with the O-ring located toward the fuel pump.

Use caution not to pinch o-ring when assembling filters. We recommend to smear a little oil on the O ring mounting the fuel filter vertically. This will provide a better seal from the O ring and limit the possibility of air being trapped inside and then coming out at an inopportune time. It is also better not to affix it but to leave it free to slightly move.

When running the engine at full power, check the fuel line from the pump to the engine. If there is a large quantity of air bubbles flowing with the fuel, there is probably a restriction in the fuel system or an air leak in at least one of the many fittings.

Be careful not to over-pressurize the fuel tanks and the shut off valve during refueling operations. You might pump a bit of raw fuel past the valve and into the turbine, and subsequently having a wet (hot!) start. We are now requiring a manual shutoff valve downstream of the automatic kerosene shutoff valve, as an additional precaution.

Hopper Tank

A hopper tank is recommended, between the main fuel tank and the engine. KingTech highly recommends the BVM UAT or its equivalent for the hopper tank! Always use a filter between the fuel pump and the solenoid valve as shown in the diagram. This is true even when using the BVM UAT! The pump may emit small particles that can block the solenoid valve from completely closing!

Prime the Pump and System

To prime fuel pump and fuel lines (or for fuel pump test purposes), it is necessary to open the manual fuel shutoff valve and run fuel pump manually. For this operation, go to the INFO menu and use the Test selection, Prime pump. This test opens the fuel valve and acts as a speed control for running the pump. (Page 26)

Extremely Important:

Pump Test allows the fuel pump to operate without the turbine running. However, if the fuel feed line is not removed from the turbine during this procedure; it will become flooded with fuel. When this occurs, the next turbine start can become highly combustible!

Before activating the pump test mode, ALWAYS remove the fuel feed line connected to the turbine, and practice how the ECU accelerates priming and have your thumb at the ready right over the "off" button.

Fuel System Connection Diagram G Model

Fuel System Connection Diagram

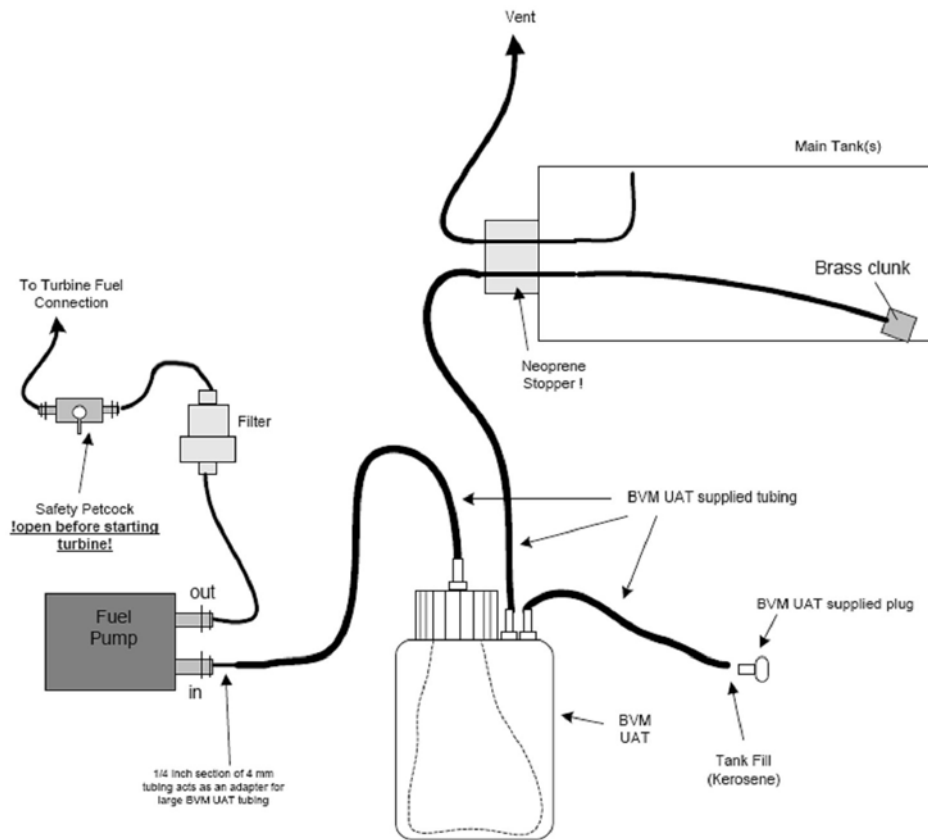

Note: All tubing 4mm(except as noted)

Fuel Pump Adjustment

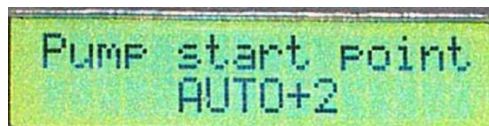

Pump Start point: Sets the power of the pump when it is started at beginning of the fuel ramp. The ECU has the ability of to automatically adjust the pump power to start it at the lowest possible speed, independently of the battery voltage and pump roughness.

AUTO mode: The values of "Pump start point" from 0 to 8 are in AUTO mode. This means that the FADEC will adjust itself the pump power to start it slowly. The value at default is AUTO+2, but after the first start you can increase or decrease the fuel flow if needed. The idea is to have a smooth start, but make sure during ramp up, temperature does not peak over 800C.

Mounting the Turbine

A two-piece, aluminum mounting bracket is included with the turbine. Place the bracket around the turbine, with the glow plug situated within the slot of the smaller bracket piece. This will help stabilize the engine along the thrust axis. The glow plug must be in the vertical position, when mounted in your model (+/- 75° of engine rotation, from the glow plug at top dead center, is the allowable deviation). Secure the engine, using four metric mounting screws and lock washers that are provided with brackets.

Other Notes on Turbine Installation

When the turbine is mounted in models with the air intake at the bottom, for example an F-16, care should be taken to prevent foreign object damage of the compressor blades.

This can be accomplished by using a strainer screen at the inlet. The screen mesh should be about 0.06 inches in width.

KingTech also offers a FOD screen as optional accessory and it is highly recommended to protect your investment.

Connections at the Turbine & ECU (G Models)

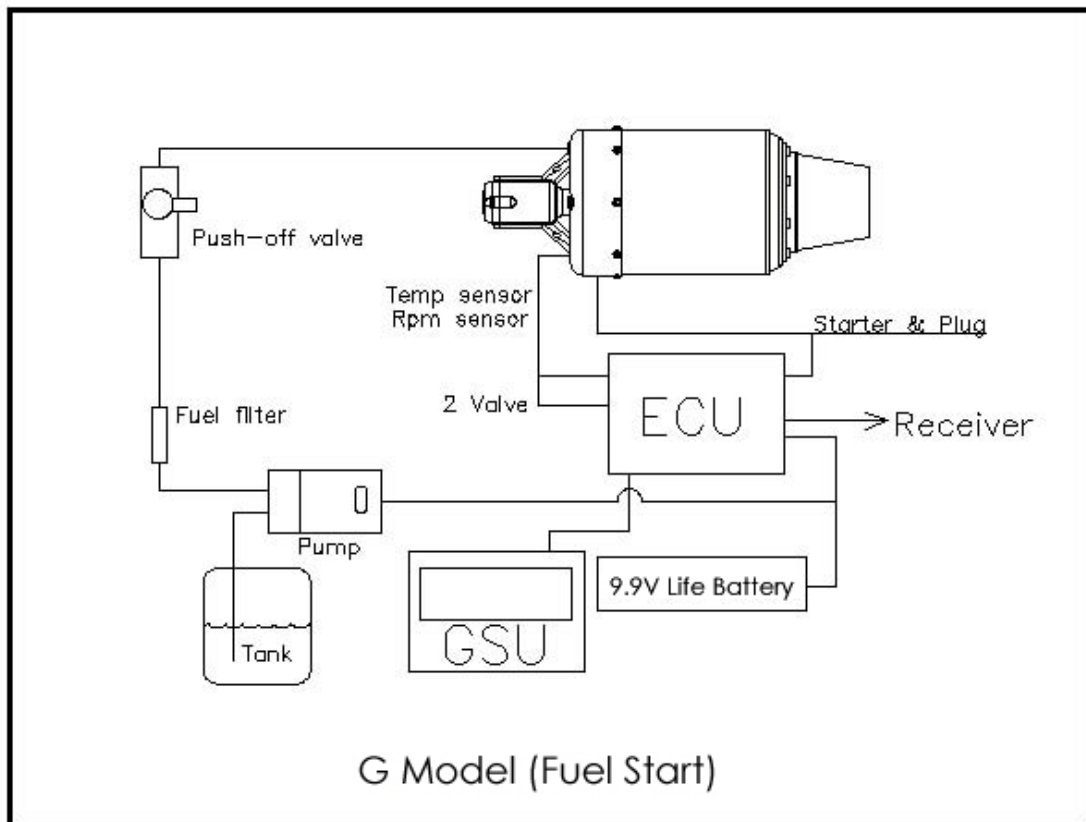

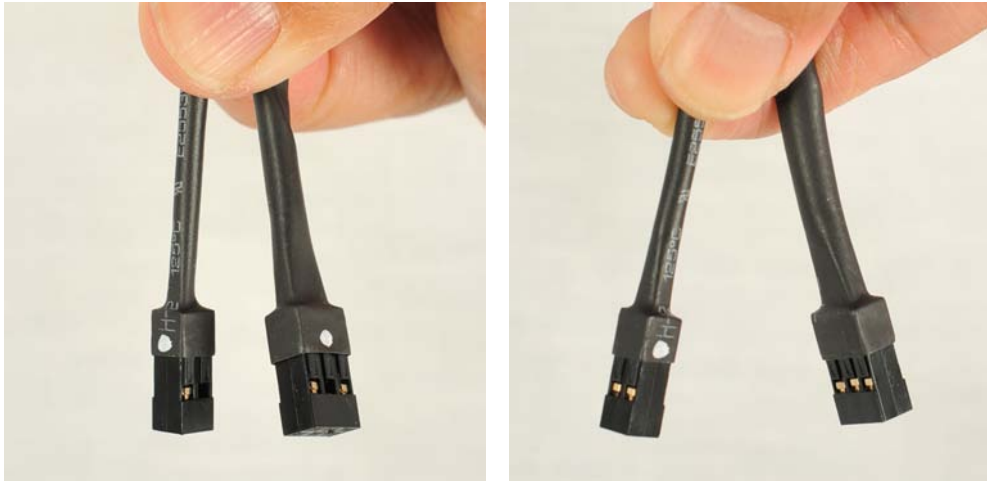
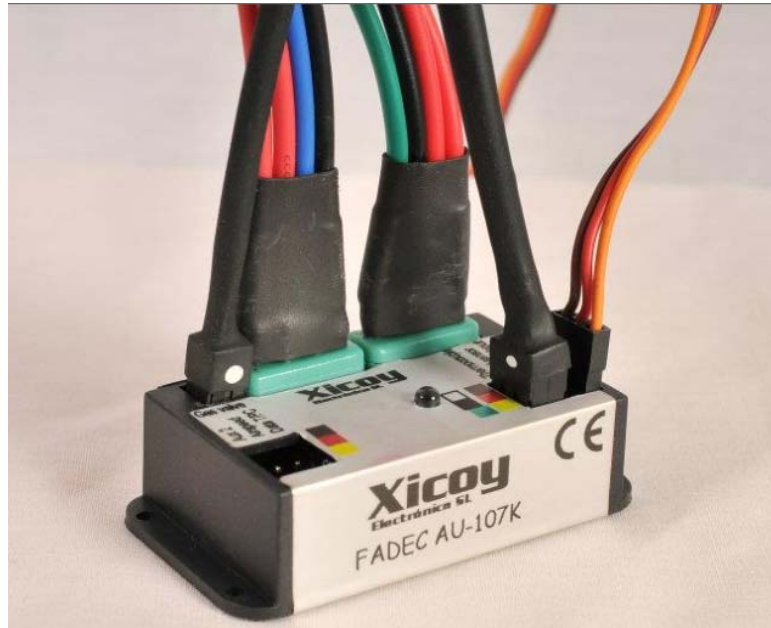

"G model Comm Cable Orientation"

In the event white dot(s) get rubbed off or the heat shrink slipped or broken, please refer to the above pictures for proper orientation to prevent fail start, please pay special attention on the orientation of the contact pins.

ECU Battery (not included)

Electrical power for all electrical components for our F/G series turbine (starter / glow plug / ECU / fuel pump / fuel and gas valves) will require a 3S LiFe pack or 7C NiMH from 2000mah to 5000mah ECU battery. For E series, a 2S LiPo of the similar capacity will do. The amount of battery capacity used per flight is approximately 300-350 mah. This includes starting and cool down. The ECU battery must not be used over 80% of its capacity, or must be recharged.

Charging the Battery - Do not charge the battery, with a charger using negative discharge pulses, when connected to the ECU. This will destroy the electronics of the ECU. The only method is to disconnect the battery from the ECU and charge it directly.

Also make it a routine to reset battery used, to zero, under Info menu by pressing the "+" button after each completed charge. This will cumulatively monitor mAh used, again, make sure you stop flying and starting charging if it becomes near 80% of the capacity.

*** 3S LiFe pack peaks at 10.8V, which may cause an error message from the GSU "Voltage Overload" and ECU will cease to function, remedy is simple, with Trim Down, stick up to actuate starter motor for 5 seconds. This will bleed the voltage down just enough to get it closer to nominal for normal operation.**

Description of the ECU

The ECU is a system for the control of a model gas turbine engine. Its main function is to control and regulate the fuel pump, providing to the turbine engine the necessary amount of fuel for safe and controlled operation, and to operate the ancillary devices for starting. The ECU measures the exhaust gas temperature, the relative position of the throttle stick and the rotor speed. It monitors all of the controls necessary to make sure that the engine stays between the user defined parameters of operations, also providing failsafe shutdown of the engine when it has detected any important anomaly. In order to make this assessment, the ECU has a rpm sensor, a thermocouple input, a throttle servo input, power connections for the fuel pump, starter, glow plug, fuel and gas valves and the battery and a data port to program and read the data in real-time from the GSU or a PC. The measurements made by the ECU are:

- Temperature of the exhaust gas
- Battery voltage
- Battery current
- Width of the throttle pulses from the radio transmitter
- Engine rotor RPM
- Engine run time.
- External analog signal (airspeed sensor)

Features:

- RPM input: Magnetic sensor up to 250.000 R.P.M.
- Temperature range up to 1000°C using a "K" type thermocouple
- PWM control of 8192 levels for pump, glow plug and starter motor.
- Adjustable power for the starter motor
- Build-in electronic brake for the starter motor to help the clutch to disengage.
- Blown glow-plug detector
- Adjustable glow-plug power
- Glow-plug temperature independent of the battery voltage
- Elapsed engine run timers

- RS232 or USB interface to PC, cable must be purchased separately.
- Black box function. Record the engine measures each 0.5sec up to 52 minutes.
- Radio link error counter
- Battery usage counter in mA/h, (reset this value on a freshly charged pack)
- Test functions for all connected devices.

Setting up the ECU

All the programming and measures are done through the GSU, Ground Support Unit. Once the ECU is programmed, it is no longer necessary and do not leave inside the airplane. The GSU has a 16 character LCD screen and 4 buttons. The first two buttons on the left side allow moving through the menus, and the two buttons on the right side (+, -) allow changing the data. Main screen, as shown in the picture, give to the user that main readings from the engine. These are the ECU status, the EGT (temperature), RPM and Fuel Pump pulse width (Pw)



In the case of an error, this screen changes to the error screen every 2 seconds.



Pressing the second button from the left (Menu Up) the second information screen is shown. In the first line you have the measure of the pulse width received from your RC system, and the relative stick position. Second line shows the voltage of the battery and the software version.

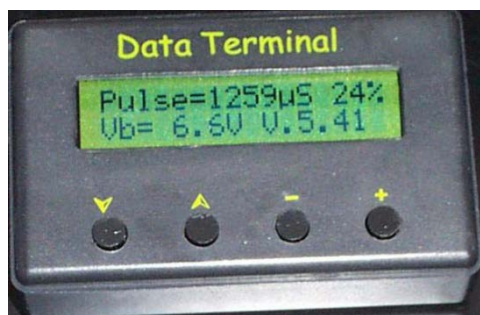

Next menu lets you to choose in four submenus, selected by pressing the button under of each Heading.

Start: To the parameters used on startup

Info: Information and test menus

Radio: Programming the transmitter throttle and trim throws, and setting of throttle curve.

Run: Set the parameters used during engine run.

It is recommended to program the learn RC first.



Learn R/C Teach the ECU to Your Radio System

Learn RC, follow below procedures to ensure learning RC for proper failsafe.

- 1) For JR and Spektrum Compatible, Power on transmitter and make sure throttle reversing is at normal, travel 100% and put Stick Down, Trim Down, then turn off transmitter.
- 1a) For Futaba and compatible, do the above except activate reversing on throttle channel
- 2) Bind Tx to Rx with stick down trim down
- 3) While Tx and Rx are powered on, make sure ECU battery is unplugged, and plug GSU into ECU
- 4) Use #2 button (second button from the left on GSU) press twice to scroll to "Start Info Radio Run"
- 5) Select "Radio" by pressing #3 button under "Radio"
- 6) To Enter, press #4 button underneath "Enter"
- 7) Stick Up Trim Up on Tx and press #4
- 8) Stick Down Trim Down on Tx and Press #4
- 9) Stick Down Trim Up on Tx and Press #4
- 10) Use #4 to scroll to "HALF EXPO", default and recommended curve
- 11) Press #2 button to save and exit.

Some button on GSU may be sensitive, make sure your pressing of button is nice and brisk; otherwise, it may flash onto the next command unknowingly.

Correct reading of throttle % by the ECU can be verified on the second screen, percentage of the throttle position is shown on, 0% in the position of engine stop (trim and stick down), 100% with stick/trim full up and between 10% and 30% at idle, (stick up trim down).

This now completes your radio setup and should only need doing again if the radio settings in the TX are changed or a different Radio is being used. **Or, you are experiencing high idle due to a broken-in pump motor, typically about 1 to 2 hours from brand new.**

On your first start after RC learned: Be patient until ECU stabilizes idling RPM, this

may take up to 1 minute or so, subsequently hold on tight to your airplane and apply full throttle, and again let the ECU to stabilize its peak RPM, then back down to idle to verify, do this a couple more times and you are ready to go.

Error "Cooling Down" message - Anytime you have a cool down message after you completed the above steps for Learn RC, you have a connection error, most likely your throttle cable is plugged in incorrectly, please check polarity and/or correct slot.

Throttle Curves

Jet engines develop the thrust exponentially, thus half RPM means approximately ¼ of thrust. On small engines with a high idle to full power rpm ratio, or in a high drag/low power planes, often only the last 1/3 of the throttle stick produce significant thrust, with the low half stick travel being not used. Although that with current digital TX the pilot can modify the throttle curve to suit his needs, from Xicoy ECU version 5.48 three throttle curves have been added to simplify the setup for most of the installations:

FULL EXPO: Mean linear RPM, it is the default setting and the mode used for all previous software versions. Thrust develops exponentially, and it is the recommended curve for big engines or/and high thrust/weight ratio planes, as it ease the control in low power used during taxi.

LINEAR: Mean that the thrust develop linearly with the throttle setting, has more resolution at lower half of the throttle stick.

HALF EXPO: An intermediate setting between the previous two modes. This is the KingTech factory setting and we are sure you will find this setting to be the most suitable.

MODE	Stick position					% of total thrust
	0% (Idle)	25%	50%	75%	100%	
FULL EXPO	Idle thrust	6%	25%	56%	100%	
HALF EXPO	Idle thrust	16%	38%	66%	100%	
LINEAR	Idle thrust	25%	50%	75%	100%	

Test Functions

The ECU provides testing functions to the starter motor, glow or burner plug, pump and both solenoid valves. These test screens are only available when the ECU is on "Trim Low" status, that is to say, recently powered up and receiving a STOP signal from the TX. Pressing the (-) button (under the "ON" reading on the screen) will energize the selected device and pressing (+) will shut down. Special care should be taken when testing the pump, as it is possible that fuel can be pumped into the engine, flooding it, and causing a hot start on next startup.

***Some LiFe chargers is capable to peak a 3S pack over 10.7V, the ECU might display "Over Voltage" and will not engage engine start mode. Please go back to Page 22 to bleed off the peaked voltage.**

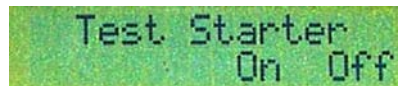

Test Starter
On Off



Test Glow-Plug
On Off

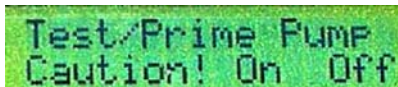

Test/Prime Pump
Caution! On Off

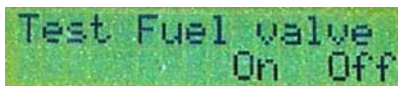

Test Fuel valve
On Off

Turbine Starting and Running

Always set-up and confirm the operation of your Auto-start installation on the test-stand, before installing into your model. This will help you to familiarize all components associated and the characteristics of different stages of turbine engine starting.

The present version of auto start uses only one channel for the entire engine functions:

To trigger the auto start cycle, the process is as follows:

- The user raises the trim. "Ready" will appear on the GSU screen. The trim and stick should be where the engine is supposedly to be to idle once running. If the trim is on "stop" position, "Trim low" will be read on the GSU.

If throttle value is higher than idle, "StickLo!" will be read.

- When "Ready" is displayed, the user should cycle the stick to full power and back to idle in order to initiate the start sequence. *** For F & G models, do not be alarmed by the starter motor engaging the rotor, this briefly actuates manual cool down***

- The burner plug is powered and checked. Once hot, the starter is engaged at reduced power (soft start). If the glow test fail, a "Glow Bad" message is displayed, and if the starter fails to arrive a minimum RPM in 2 seconds, a "start bad" message is issued, and the auto start function aborted.

- **Ignition** – (Ambient to plus 4C) When the rotor arrives at more than the "ignition max rpm" programmed parameter the starter is disconnected, the ignition fuel is being introduced; you could recognize this by the clicking sound of burner fuel solenoid and the pulsating of fuel pump. Once this fuel delivery is engaged, you would want to hear a very positive "pffffff" ignition.

- **Preheat** – (up to 72 C) Once the temperature climbs for 2 to 4 degrees from ambient, Preheat stage commences, flame is something you do not want at this stage. If flame is present, abort (trim down) you could either reduce Preheat fuel or increase preheat RPM. What you want to see is a steady climb of temperature up to 72C.

- **Switch Over** – (up to 200 to 300 C) This is the stage that the main fuel also opens

and a slight yellow to bluish flame is expected, while starter motor drives the rotor even faster in preparation for fuel ramp.

• **Fuel Ramp** - Some popping and some flashes of yellowing blue flame is expected. At this stage, the burner valve is closing while the pump and start motor drive the engine up to idle temperature and RPM, once Running, your transmitter takes over the engine.

- Watch out for temperature hanging at a certain stage, primarily Ignition and/or Preheat. This will potentially accumulate fuel and an undesirable wet-start may occur.
- It'd be a good practice to extend your GSU to be viewed in-line with the tail cone to have a sighting of possible fuel dripping or flame.
- Before you call tech support on start up related issues, please have enough above information to facilitate an effective support.

Turbine Stopping and Cooling

- The user can finish the sequence at any moment, simply setting the trim to "off" position. If the engine was on "running" phase (above idle rpm), a cooling sequence will be triggered, cycling the starter motor until the EGT is below the minimum programmed temperature. This cooling sequence will be aborted if the trim is raised again.
- If the engine is hot (EGT higher than the minimum temperature) at the moment that the user triggers the auto start cycle, then the FADEC will begin a cooling cycle until the temperature is below 100C.

Manual cool down:

In the event if engine does not go into the cool down mode after the turbine shuts down or flames-out, the user can lower the trim, and advance throttle stick to trigger cooling from starter. Make sure you simulate the auto cooling sequence and monitor the real time temperature and do not leave motor running to longer than a couple of seconds.

Another option is to unplug reconnect power to ECU, this power cycle will enable ECU to recognize that the engine temperature is still higher than normal, and should engage auto cool down.

RUN Menus

Under this submenu, the parameters used for the engine during normal run can be modified. Note: Some of these menu parameters cannot be changed by user. It was factory set for best operation and to protect turbine. ***Please do not change these values set by factory. This may void your warranty!***

Full power speed: On this screen you can set the RPM that the engine will run at 100% throttle. If the engine manufacturer has set a maximum limit, you will only be able to reduce the max RPM.

Idle speed: Set the RPM that the engine will run when the ECU receive IDLE Command. While the engine is running, the ECU will adjust the rotor speed accordingly the throttle position in a closed loop system. (For rough idle, please refer to TROUBLESHOOT towards the end of this manual)

STOP speed: Set the minimum RPM that the engine is allowed to run. The ECU will shut down the engine if the rotor speed is below this setting.

Start/Min temperature: Set the minimum temperature that the engine is allowed to run, and in manual start operation, sets the temperature from which the pump begin to run. 100 Celsius.

Maximum temperature: Set the maximum temperature that the engine is allowed to run. The ECU will reduce the acceleration rate if the EGT approaches to maximum and will reduce the pump power if necessary to keep the temperature below the maximum, but it don't will cut the engine if the temperature is too high, it will try always to keep the engine running by reducing the fuel flow. 850 DEG C

Acceleration delay: Set the acceleration time on the engine. Higher the values, slower the acceleration. The real acceleration is calculated using a complex algorithm that take in to account this value, temperature, current RPM, commanded RPM, and the tendency of EGT and RPM.

Deceleration delay: Similar to the acceleration, but used during throttle down. Higher values mean slower deceleration.

Stability delay: When the engine is running at constant throttle setting, the ECU is adjusting continuously the pump power so that the rotor RPM mach exactly with the

throttle signal. The speed of which the ECU adjust the pump power is set by this parameter. A value of 100 usually is the best for all engines. A too low of a value can cause instability on the RPM.

Pump Limit: The ECU can give to the pump the full battery voltage, but in most cases the voltage needed for the pump is only a fraction of the full battery voltage. Limiting the pump give a much smoother control of the engine and prevents that the pump could receive excessive voltage in the case of a problem in the fuel circuit, a clogged filter for example. This excessive power will cause a high pressure on the circuit that can cause leaks or blown tubes. Modifying this parameter is similar to reducing the battery voltage, so the accel and decel times will be modified. The most ideal is to have the limit set at the lowest and still be able to reach full max RPM, run the engine, check and annotate the Pw of the pump displayed on the first screen when the engine is running at full power and then use this value as pump limit, increasing it in a 15%-20% to give a bit of margin for weak batteries and pump wear. Once the new value set, adjust the accel and decel delays for best engine handling.

List of FADEC STATUS Message Codes

Here is a list of possible messages shown on the data terminal screen and their meaning.

TrimLow: Indicates that the signal received from the transmitter corresponds to the lowered trim, that is to say, engine OFF.

Ready: Indicates that the engine is ready for starting, and that the transmitter signal corresponds to IDLE, (green LED lit)

StickLo!: This indicates that the throttle stick is in the IDLE position, the engine will not start with the stick in this position.

Glow Test: Verifying of glow plug

StartOn: Test of the starter

Ignition: Gas ignition phase.

Preheat: Phase of heating of the combustion chamber after detecting gas ignition.

FuelRamp: Phase of fuel acceleration until IDLE IS reached.

Running: Engine working correctly, pilot have full control of engine power.

Stop: Engine off.

Cooling: Starter operating to cool the engine. (This message would also display if ECU is connected incorrectly, most likely the throttle cable, please check all connections to and from the engine and ECU)

GlowBad: Defective or disconnected glow plug, or a short of glow system wiring.

StartBad: Defective starter, insufficient RPM reached during start.

Low RPM: Engine speed below the minimum.

HighTemp: Excessive temperature

FlameOut: Exhaust GAS Temperature below the minimum.

List of FADEC Warning Message Codes:

RC SIGNAL LOST/INCORRECT: The signal received from the RX is wrong (outside calibration margin) or absent.

PUMP LIMIT REACHED: The FADEC has increased the pump power up to the value set on the "Pump Limit" parameter, but the engine has not arrived to the full power. Causes could be flat battery, fuel restriction or anything that can cause a reduction in the fuel flow.

xxxx OVERLOAD: An excessive current is detected from the specified output.

Diagnoses

During engine operation the FADEC measures and stores all the engine operating parameters recorded during the last the 51 minutes of operation. These measures can be downloaded later to a PC to study the behavior of the engine in flight and to diagnose any possible problems. Also, after each cycle of operation, the FADEC stores the last cause of shut down and the values of RPM, temperature and pump power at the moment of shutdown. In order to access these measures, it is necessary to reinitialize the FADEC (shut down and powerup).

Set the trim down (TrimLow) and push the left button on the display. The FADEC will show the cause of shutdown and the measured values at the moment of shut down.

These are as follows:

Diagnosis messages:

UserOff: The engine has been shut down because it has received the shut down command from the transmitter.

FailSafe: The engine has been shut down because of loss of signal from the transmitter. Once Ecu detects a loss or invalid RC signal for over 0.5 second, it sets engine power to idle, and if after another 1.5 seconds a valid signal is still not received the engine is shut down.

LowRPM: The engine has been shut down because the RPM has dropped below a minimum. Cause could be lack of fuel, air bubbles, problem with the batteries, or defective RPM sensor.

FlameOut: The engine has been shut down because the temperature has dropped below the minimum of (100°C). (If not shut down manually, usually a thermocouple failure).

RCPwFail: Lack of power from the radio receiver.

K-45G Specifications:

Diameter: 76mm (2.99")

Length: 195mm (7.68")

Weight: 700g (1 lb. 8.6 oz.)

Max. RPM: 170000

Thrust: 4.5 kg @ 15° C (9.9 lb @ 15° c)

EGT: 700°C max

Fuel consumption: 155 g / min (5.46 oz / min)

Fuel: Diesel, Jet A1, Kerosene

Lubrication: 5%

Maintenance cycle: 25 hr USD300

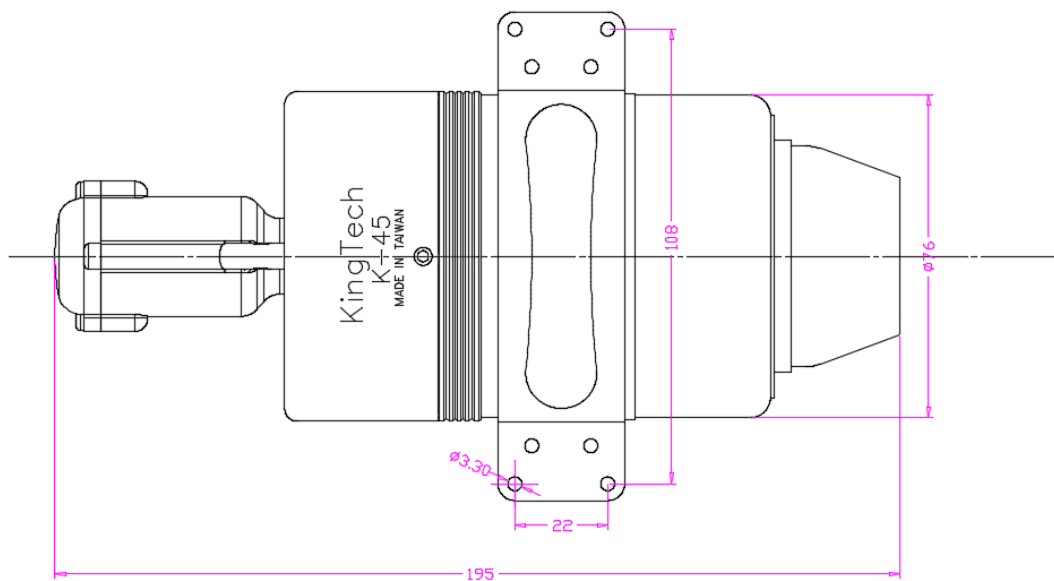

K-60TP Specifications:

Length: 385mm (15.15")

Weight: 2400g (5 lb. 4 oz.)

Maximum RPM: 16000

Power: 7.3KW (7000RPM)

EGT: 700°c max (1292°f max)

Fuel consumption: 240 g / min (8.46 oz.) Fuel: Diesel, Jet A1, Kerosene

Lubrication: 5%

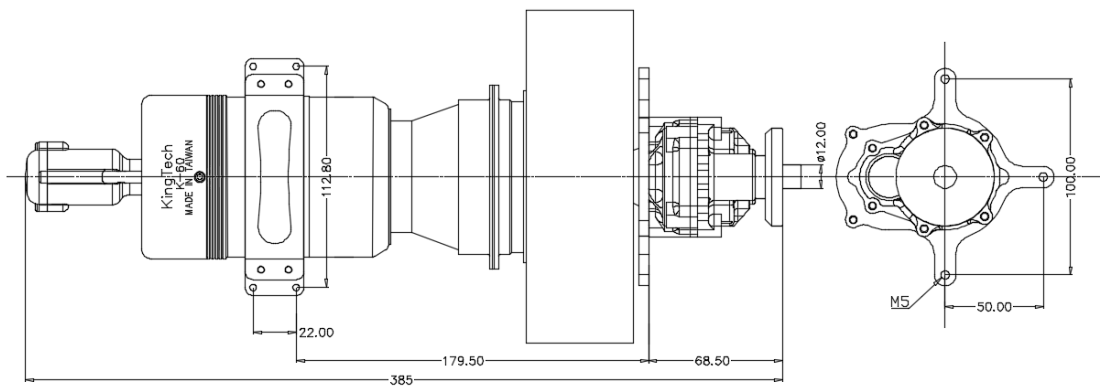

K-60G Specifications:

Diameter: 82mm (3.22")

Length: 228mm (8.97") - including starter

Weight: 850g (1 lb 14oz) - including starter

Maximum RPM: 162000 MAX (up to)

Thrust: 6 kg @ 15° C. (13.22 lb @ 15° C)

Idle: 50000rpm

Exhaust temperature: 700°C

Fuel consumption: 195 g / min (6.88 oz / min)

Oil: 5% (refer to page 13 for restrictions and recommendations)

Fuel: Diesel, Jet-A, Kero

Maintenance cycle: 25 hr USD300

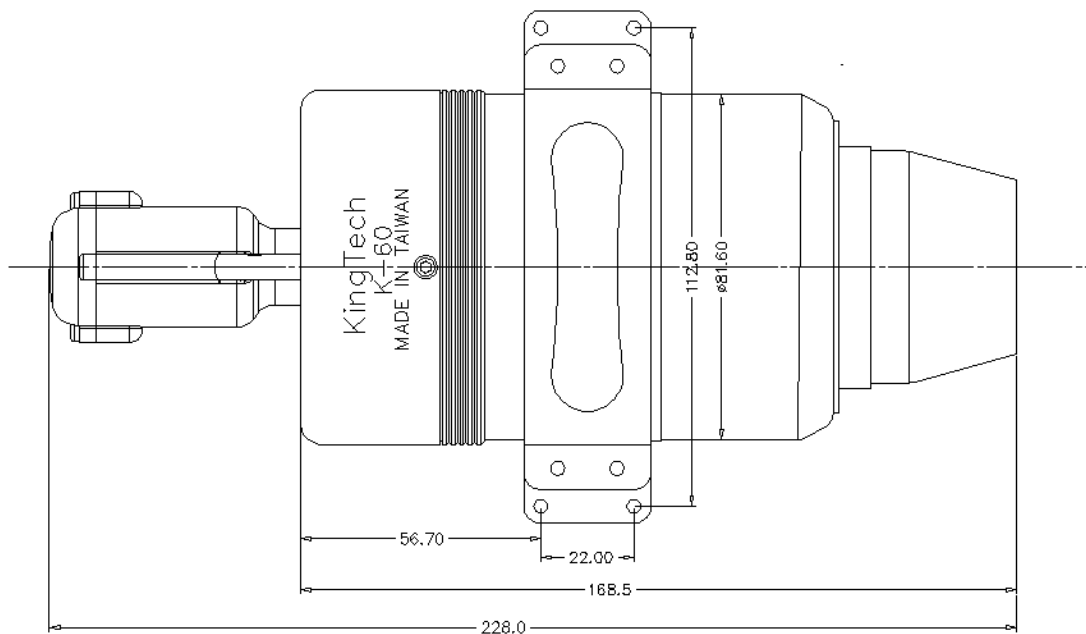

K-80G Specifications:

Diameter: 95.25mm (3-3/4")

Length: 254mm (10") - including starter

Weight: 1304 g (2 lb. 14oz.) - including starter

Maximum RPM: 145000 (up to)

Thrust: 8618 g @ 21.1° C. (19 lb. @ 70° F.)

Idle: 45000rpm

Exhaust temperature: 650°C

Fuel consumption: 239 g / min (8.46 oz / min)

Oil: 5% (refer to page 13 for restrictions and recommendations)

Fuel: Diesel, Jet-A, Kero

Maintenance cycle: 25 hrs or 30hrs with KT oil, USD300

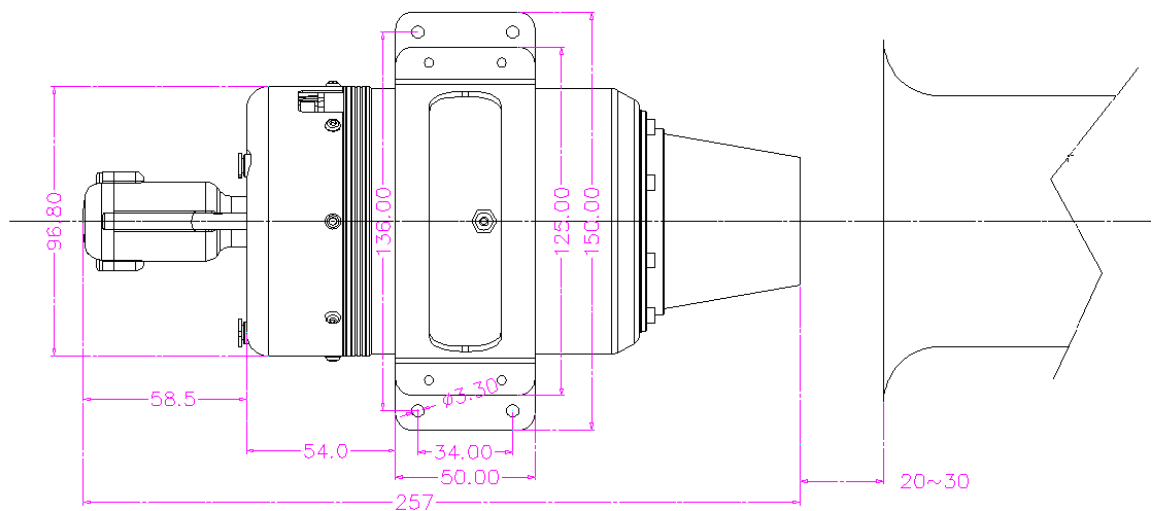

K-100G Specifications:

Diameter: 95.25mm (3-3/4")

Length: 254mm (10") - including starter

Weight: 1300 g (2 lb. 14oz.) - including starter

Maximum RPM: 142000 (up to)

Thrust: 10 KG @ 15° C. (22 lb. @59° F.)

Idle: 43000rpm, 0.85 pound

Temperature at NGV: 650° C

Fuel consumption: 350 g / min (11.84 oz / min)

Oil: 5% (refer to page 13 for restrictions and recommendations)

Fuel: Diesel, Jet-A, Kero

Maintenance cycle: 25 hr USD300

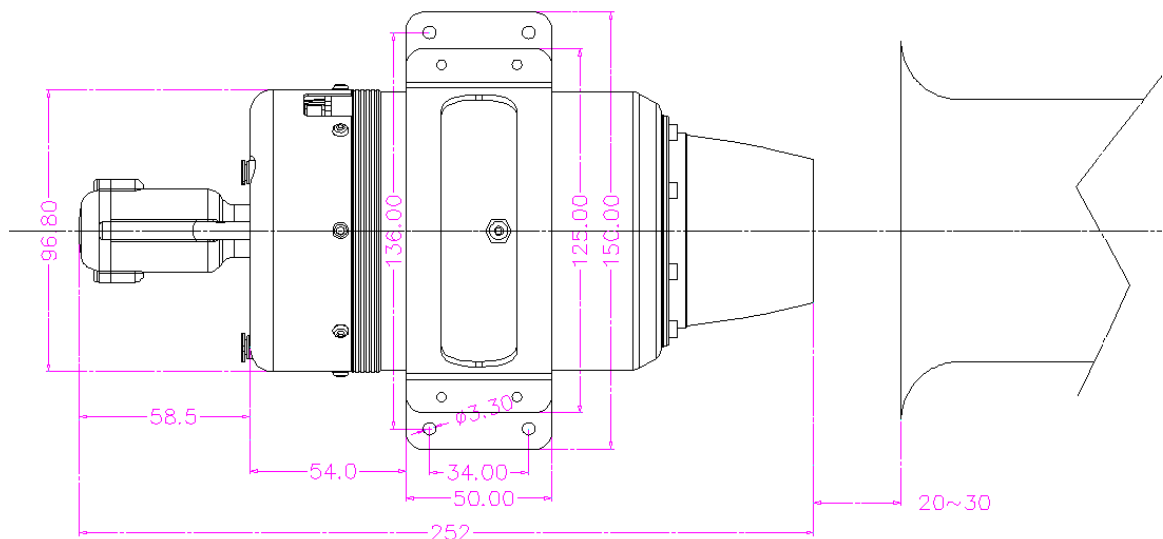

K-120G Specifications:

Diameter: 95.25mm (3.75")

Length: 254 mm (10")

Weight: 1280 g (2 lb. 14oz.)

Maximum RPM: 140000

Thrust: 12 KG @ 15° C. (27 lb. @59° F.)

EGT: 700°C max

Fuel consumption: 385 g / min (11.84 oz / min)

Fuel: Diesel, Jet A1, Kerosene

Lubrication: 5%

Maintenance cycle: 25 hr USD300

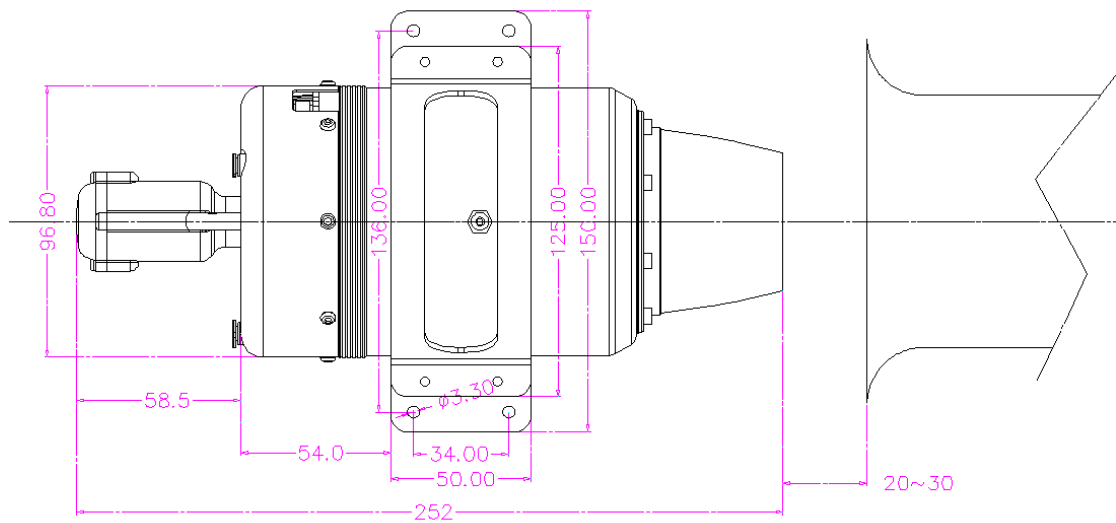

K-140G Specifications:

Diameter: 113mm (4-1/2")XJ0

Length: 270mm (10-1/2") - including starter

Weight: 1650 g (3lb. 10oz.)

RPM Range: 33,000 - 123,000 RPM (up to)

Thrust: 14 kg - 15° C (31 lbs @ 59° F)

Exhaust gas temp: 700°C

Fuel consumption: 400g / min—average (14.1 oz / min)

Oil: 5% (refer to page 13 for restrictions and recommendations)

Fuel: Diesel, Jet-A, Kero

Maintenance cycle: 25 hr USD300

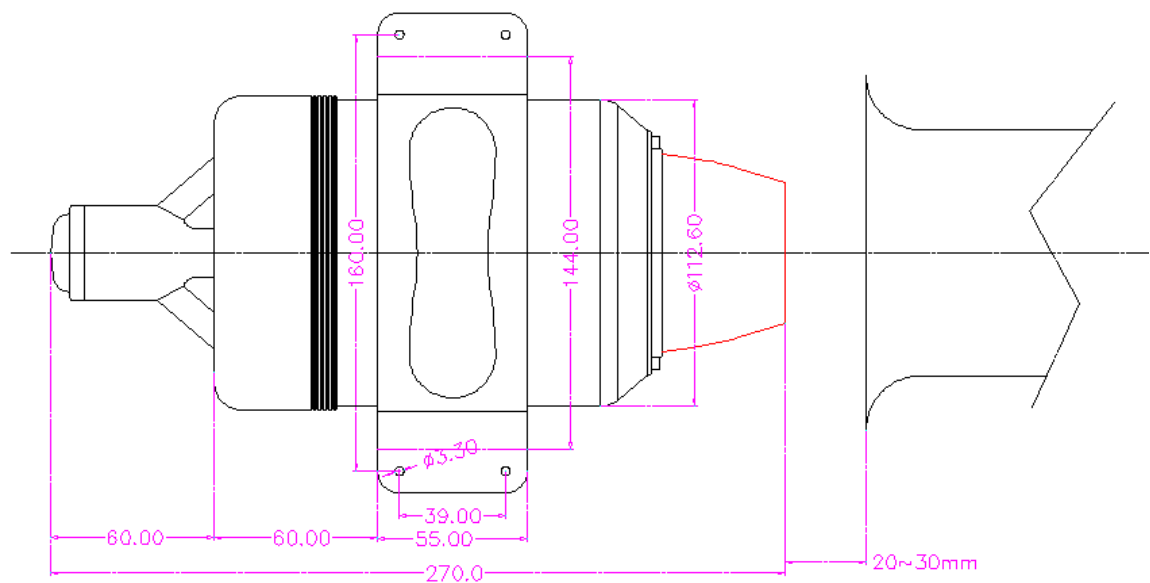

K-180G Specifications:

Diameter: 114mm (4-1/2")

Weight: 1644g (3 lb. 10oz.)

RPM Range: 35,000 - 123,000 RPM (up to)

Thrust: 18 kg or 40 lbs

NGV Temperature: 520°C to 700°C

Fuel consumption: 550g / min (19.4 oz / min)

Lubrication: 5% (refer to page 13 for restrictions and recommendations)

Fuel: Diesel, Jet-A, Kero

Maintenance cycle: 25 hr USD300

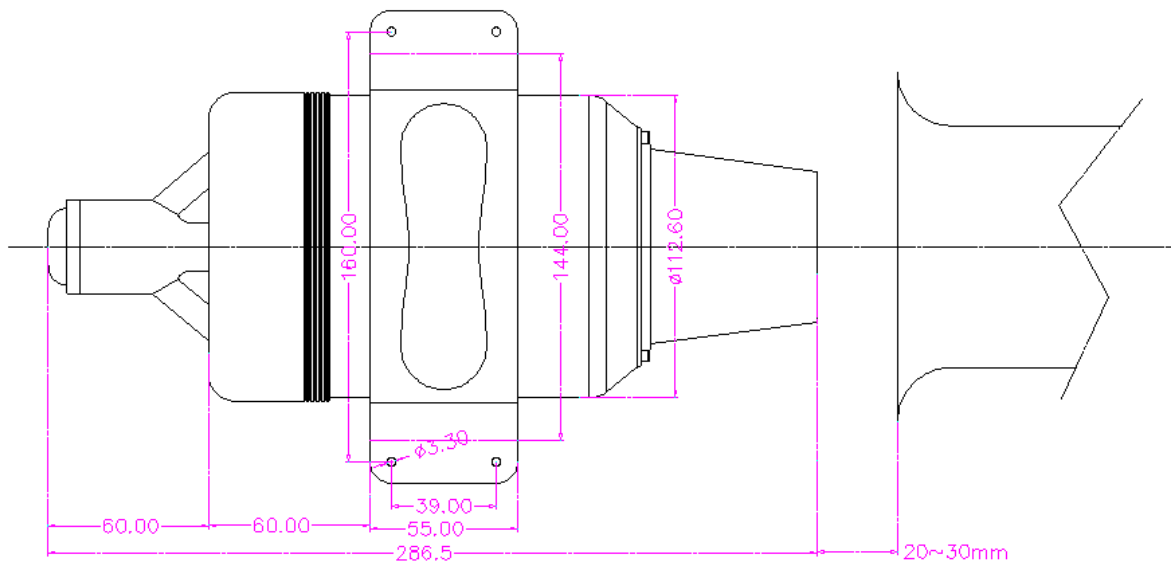

K-210G Specifications:

Diameter: 112.6 mm (4.43")

Length: 286 mm (11.26")

Weight: 1650 g (3 lb. 10oz.)

RPM Range: 33,000-120,000RPM (up to)

Thrust: 21 kg at max RPM (46.3 lbs at max RPM)

EGT: 650°C

Fuel consumption: 590 g / min (20.8 oz / min)

Fuel: Diesel, Jet-A, Kero

Lubrication: 5%

Maintenance cycle: 25 hr USD300

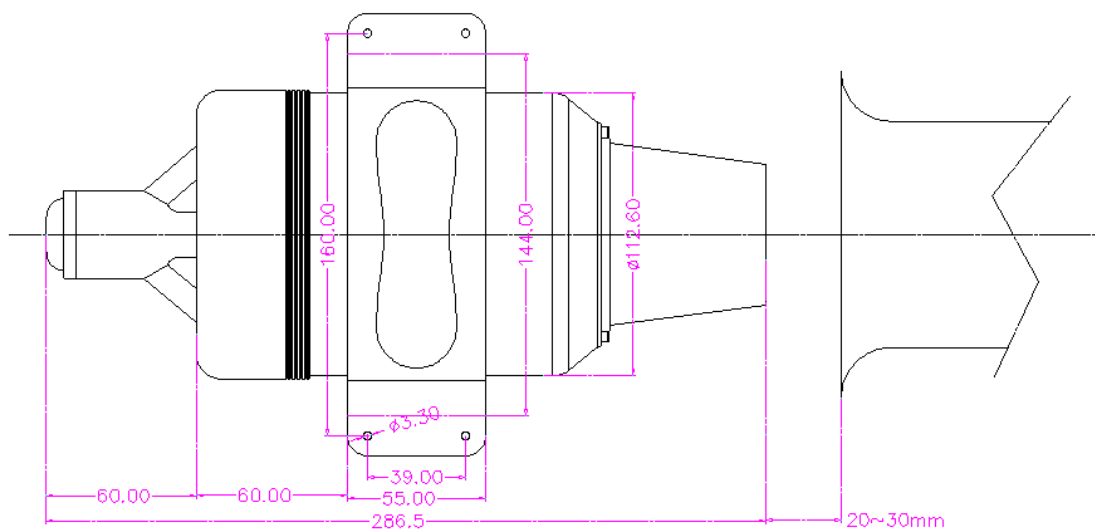

Maintenance cycle includes:

- Turbine dismantle
- Replace of bearings and other components determined by technical staff
- Balance correction
- Cleaning of injectors and chamber
- Turbine assembly
- Test and adjust if necessary

G Model Components List

Engine

Engine Control Unit (ECU)

Ground Support Unit (GSU)

Wiring harness and Tubing set

JR TYPE male to male, throttle

Fuel Pump, Filter and Shutoff Valve

Fuel Inlet Attachments

Manual

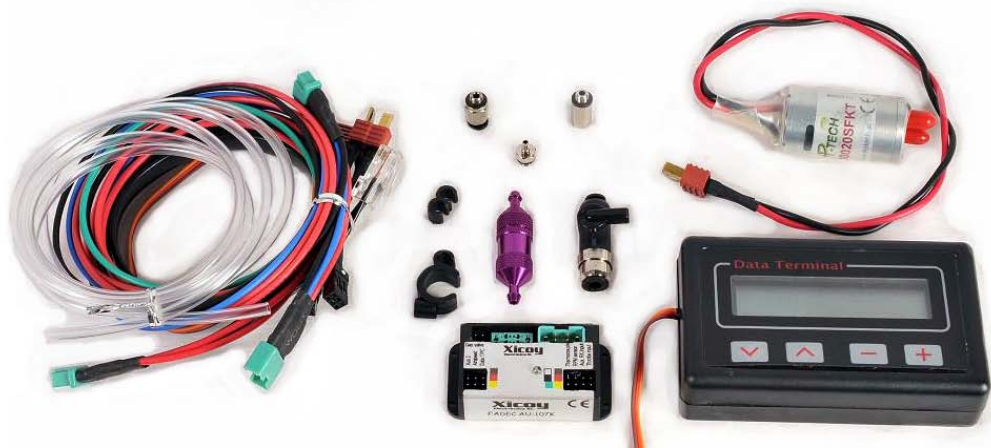

KingTech Turbines Fuel Start Operating Guide:

1. Please install engine on a simple stand to familiarize components and starting sequence.
2. For ECU battery pack, use 3S LiFe pack at 9.9V or 7S NiMH at 8.4V, anytime your residual voltage falls under 7.9V the engine may not start.
3. When Learning RC, disconnect ECU battery to avoid initiating a starting sequence
4. If the combustion chamber of the engine is not properly cooled after a fail start, a wet start may or may not occur on the subsequent attempt, please refer to below to avoid a wet start.
5. If and when your engine fails to start, there may still be residual flame and fuel remain in the combustion chamber, please do the following to avoid a wet start:
 - a. Stick Low, Trim Low
 - b. Move Stick forward to activate rotor to further cooling the chamber.
 - c. Wait at least 3 to 5 minutes before resuming
6. Two of the most important parameters for fuel start engines in reference of reducing flame during start up, please consider leaning by decrease value on following parameters, say 10 to 90% from existing:
 - a. Ignition Pump PW
 - b. Preheat Fuel
7. In some cases, if the above #6 does not help enough, one could also do the following:
 - a. Decrease given stage starter power and RPM to facilitate temperature raise.
 - b. Increase given stage starter power and/or RPM to decrease flame.

8. Try to monitor GSU during start up and sight it towards tail cone to take a close look at given stage, whether or not EGT is climbing or flame or fuel dripping is present.
9. During startup, occasional poppy yellow to bluish flame with good velocity is expected and is absolutely normal and healthy; it is the slow orange reddish flame that would be of concern.
10. Before you call-in for tech support on startup, make sure you know which of the four stages that it is or isn't doing what, ie. What temperature it is hanging, any flame or dripping of fuel... Four primary stages of startup: Ignition, Preheat, Switch Over, Fuel Ramp. It would be a good practice to extend your GSU to be able to view in-line towards the tail cone to watch out for the presence of flame or fuel.

K-60G Turboprop Operating Guide:

Make sure propeller is well balanced, unbalanced props will cause failure to the Gearbox and airframe, particularly the engine mount and bracket and may cause serious injuries or worse.

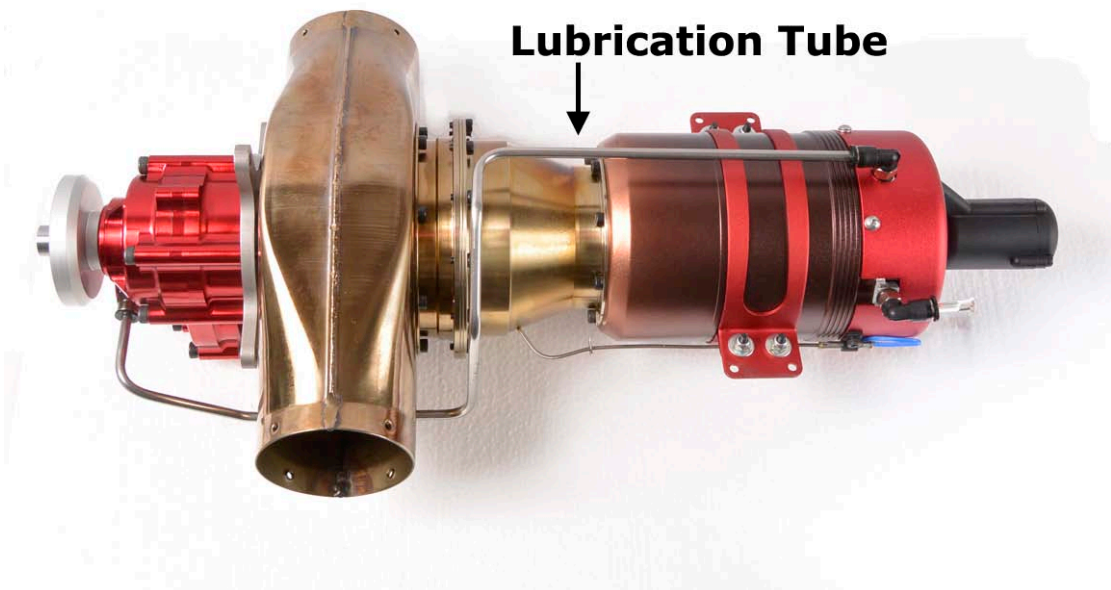
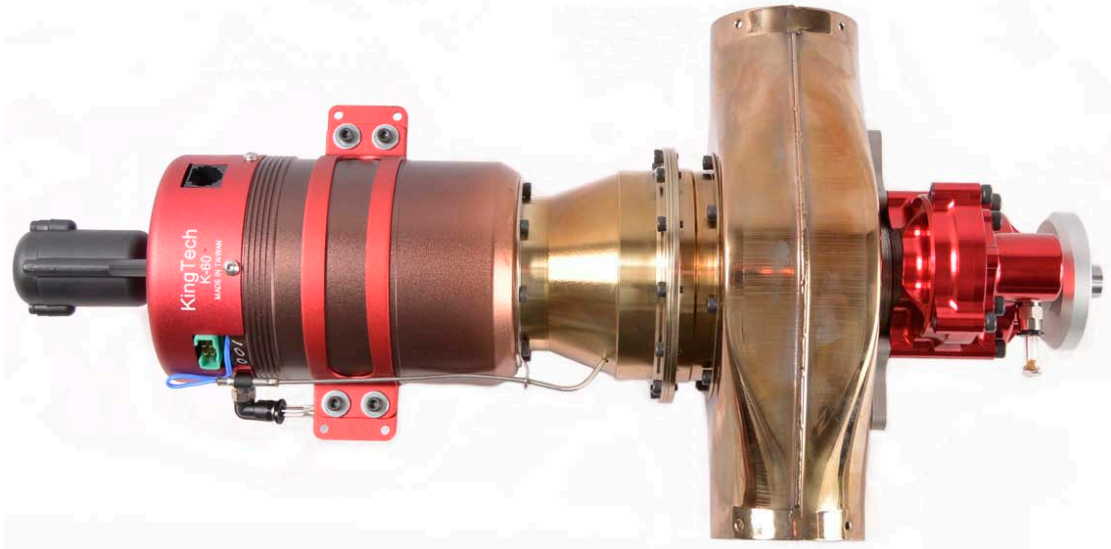

Install Lube Out First



**and then Install
Lube In**

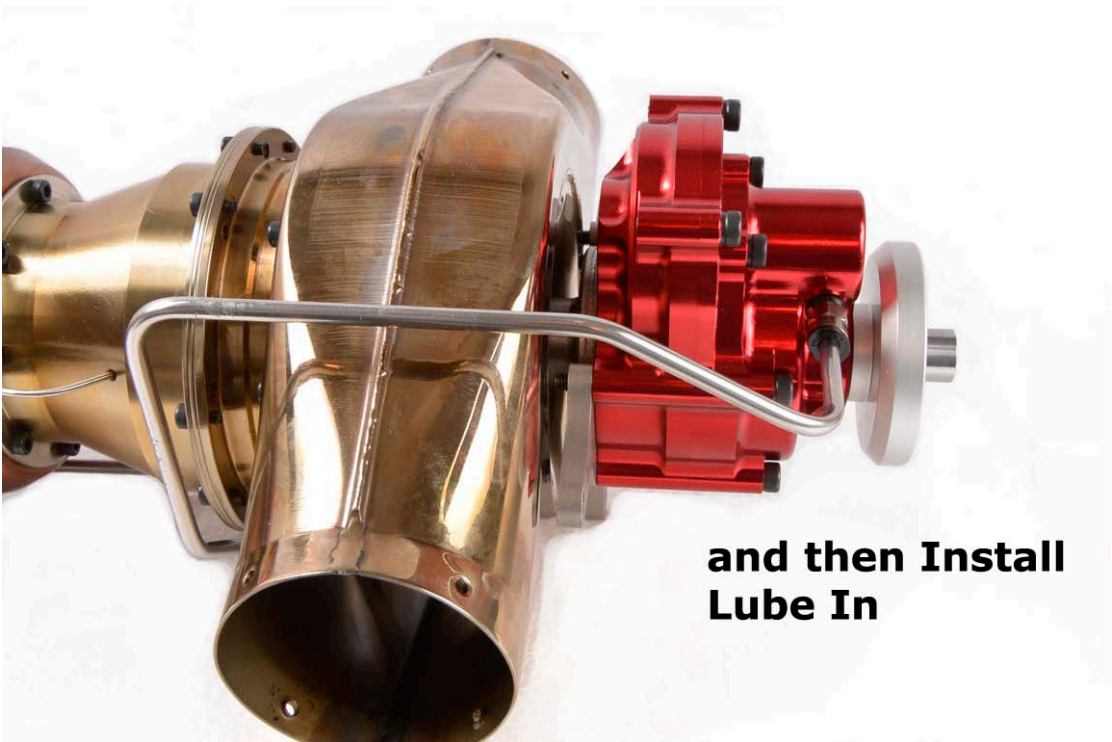

KingTech K-60TP is designed to be running at a high load but low RPM. The ideal prop would be turning at 5000 static and unload only up to 7000RPM. This would ensure max output and longevity of engine. Please use no smaller than 24x16x3b, as it would

provide 5500/7500RPM, while a 24x20x3b would achieve the sweet spot of 5000/7000RPM.

RPM	PWR (KW)
2000	3.9
2500	4.6
3000	5.2
3500	5.7
4000	6.1
4500	6.5
5000	6.8
5500	6.9
6000	6.9
6500	7.1
7000	7.3
7500	7.1
8000	7.0
8500	6.4

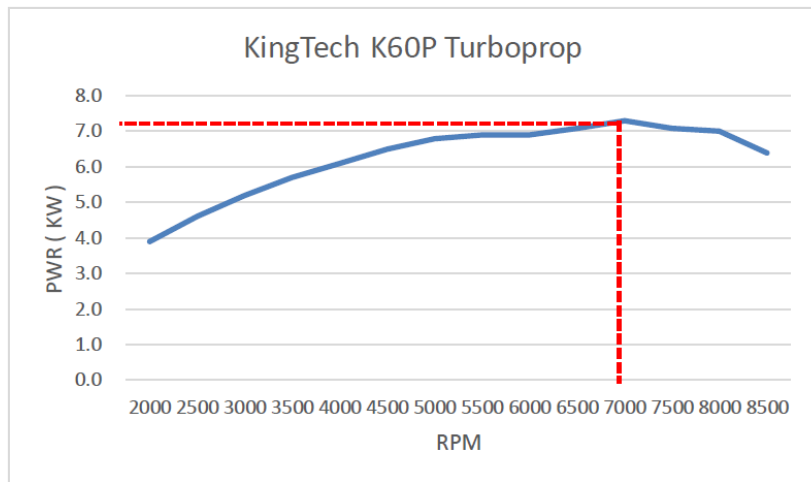

Fuel Start Parameters	K-45	K-60
Pump start point	Auto +2	Auto+2
Pump start ramp	15	6
Glow power	7.4V	7.4V
Low battery	6.7V	7.0V
Starter power Ignition	40	40
Starter power Fuel Ramp	85	90
100% starter power	85000 Rpm	65,000 Rpm
Rpm off starter	28000 Rpm	26,000 Rpm
Rpm to reconnect	23000 Rpm	24,000 Rpm
Rpm ignition K	5000 Rpm	5,000 Rpm
Pump pw ignition k	20	21
Engine min flow	50%	50%
EGT end preheat	72c	68 c
Rpm preheat	10,000	10,000 Rpm
Rpm fuel ramp	15,000	13,000 Rpm
Preheat fuel	30%	35%
Ignition time out	30 s	30 s
Start mode		Auto-Kero

80 & 100 Fuel Start Parameters**140 through 210**

	Kero	Diesel	Kero	Diesel
Pump start point	Auto +2		Auto +2	
Pump start ramp	10		5	8
Glow power	7.3V		7.3V	
Low battery	6.0V		6.0V	
Starter power Ignition	70		70	
Starter power Fuel Ramp	130		180	
100% starter power	15,000		15,000	
Rpm off starter	19,000		19,000	
Rpm to reconnect	18,000		18,000	
Rpm ignition K	2,000		2,000	
Pump pw ignition k	23	18	23	18
Engine min flow	80%		80%	
EGT end preheat	72c		72c	
Rpm preheat	5,000	*6000	5,000	*6000
Rpm fuel ramp	10,000		10,000	
Preheat fuel	28%	18%	28%	18%
Ignition time out	30s		30s	
Start mode	Auto Kero		Auto Kero	

*** Preheat RPM for Diesel could be dialed back down to 5,000 or even 4,000 during winter.**

Above figures are for references only and subject to further adjustment in accordance to different density altitudes, fuel restrictions and other variables, please refer as the direction of adjustment for different fuels.

TROUBLESHOOT

High and Rough Idle –

- 1) Please relearn RC
- 2) If relearn RC didn't help, run engine at full RPM, take a look at the value of PW, multiply 1.2, reestablish pump limit under RUN menu and relearn RC.
- 3) If above didn't help either, you may have a fuel pump problem, please send it in for evaluation.

ECU Fails to Learn RC

Go to the second screen on the GSU and makes sure you have a reading on "Pulse=" when the TX is set in the 3 relevant positions (stop, idle, full power).

If Zero, then it is most likely a hardware problem. Throttle lead may be damaged or in the wrong port or ecu/receiver defective.

If same reading in all 3 positions, throttle lead is connected in the wrong channel on the RX

Then you should check the value of the readings.

STOP should be between 900 μ s and 1000 μ s, Idle should be between 1200 μ s and 1400 μ s

Full power should be between 1900 μ s and 2100 μ s

Idle should be in between STOP and Full, at least 100 μ s higher than STOP position and 500uS lower than full power position, and be stable, same readings should be obtained after resetting the TX and in all flight modes. For example, a AUTOTRIM function will center the trim each power up, changing the IDLE position.

Readings outside these limits mean an improperly setup on the transmitter, should be corrected on transmitter.

Once checked the above, then we are sure that the problem is that customer is not doing the learning procedure correctly.

The usual failures done during procedure are not using the "+" key to confirm the position, or skipping one step, or raising the stick before the trim, some model set ups have a security function for electric flight where the stick is disabled if the trim is not raised first, to prevent sudden startup of electric motors that can injury the operator.

KingTech Turbines International

289 S SANTA ANITA AVE

PASADENA CA 91107

United States

Email: kingtechturbines@gmail.com for sales and tech support only
mail@kingtechturbines.com for administrative inquiries

Website: www.kingtechturbines.com

626-399-7588 Barry's cell/text for tech support only

Skype: barrymhou

Line: barryhou1

626-712-8751 Dirk's cell/text for tech support only

Engine Model: _____

Serial Number: _____

* Before you call for tech support, make sure your engine is properly registered at www.kingtechturbines.com and with above information ready.

* When sending in an engine for service, please make sure you have included at least the ECU and a Service Request Form (following page or www.kingtechturbines.com) filled out, or will compromise service priority.

* When checking up on status of an engine sent in for service, do not call, please email with history and serial number of engine. Do not call to see if we have received the engine, you have that information through tracking.

KingTech Turbines Co., Ltd.

No.198, Ln. 818, Gongxing Rd.

Pingtung City, Pingtung County 90086

TAIWAN

886-8-751-0065

For additional information on the ECU, please go to:

<http://www.espiell.com/FAD10.pdf>

Revision Date: Aug. 2015, 15th Edition

MNM©2009
KTT©2015

Engine sent in without this form will not be serviced until supplied

SERVICE REQUEST FORM

SHIPPING ADDRESS: 289 S. SANTA ANITA AVE. PASADENA, CA 91107

DO NOT SEND IN ENGINE WITHOUT ECU

CUSTOMER INFORMATION			
NAME		Date	
ADDRESS			
PHONE			
EMAIL			

TURBINE INFORMATION				
MODEL	<input type="checkbox"/> K-60	<input type="checkbox"/> K-100	<input type="checkbox"/> K-170	<input type="checkbox"/> K-210
	<input type="checkbox"/> K-80	<input type="checkbox"/> K-140	<input type="checkbox"/> K-180	
SERIAL #	for older models, the s/n can be found on exhaust cone			
PURCHASE DATE		<input type="checkbox"/> NEW	<input type="checkbox"/> USED	
FUEL USED	<input type="checkbox"/> JET A1	<input type="checkbox"/> KERO	<input type="checkbox"/> DIESEL	
OIL USED	BRAND		% ADDED	
ECU BATTERY TYPE			CAPACITY	

COMPONENTS INCLUDED IN THE BOX			
<input type="checkbox"/> ENGINE	<input type="checkbox"/> GSU	<input type="checkbox"/> VALVES	<input type="checkbox"/> WIRES
<input type="checkbox"/> ECU	<input type="checkbox"/> PUMP	<input type="checkbox"/> ECU CABLE	<input type="checkbox"/> FOD SCREEN

PROBLEM DESCRIPTION